

# Pilot's Guide

# KFC 325

Bendix/King Digital Flight Control System

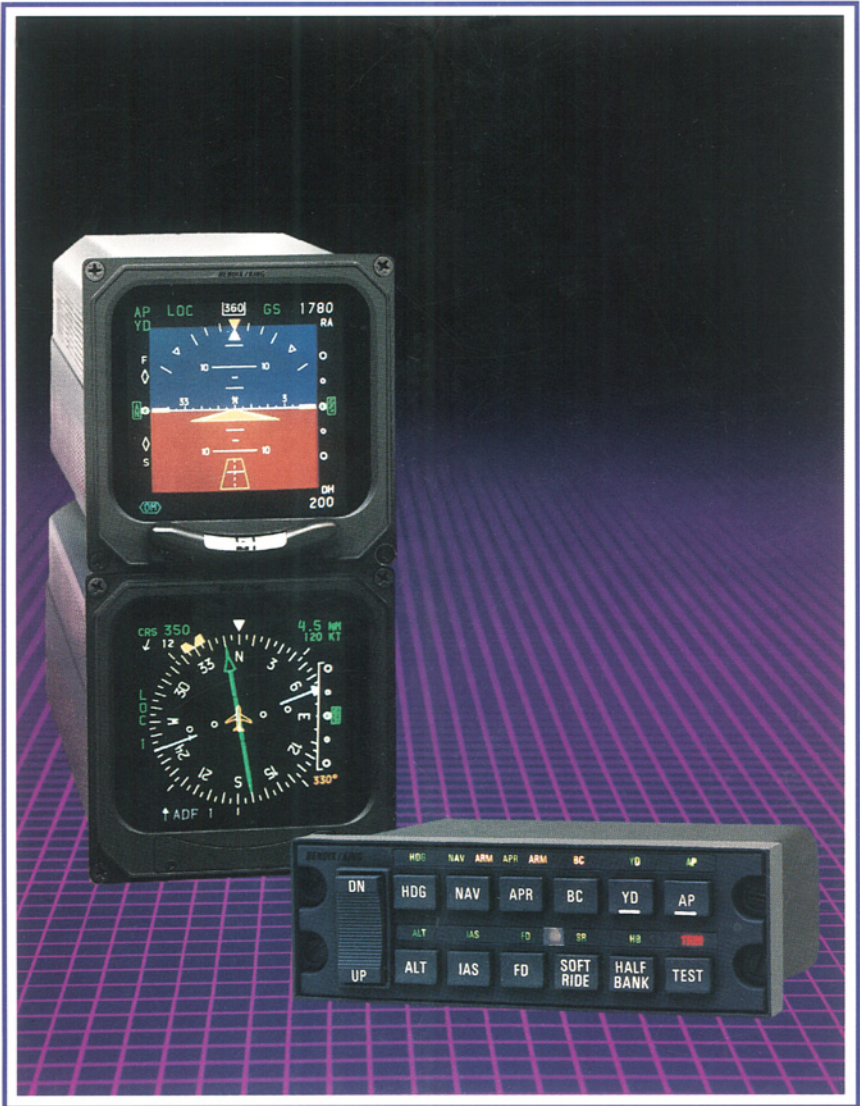

# Table of Contents

---

## PILOT'S GUIDE

<b>Introduction</b> .....	1.1
<b>System Configuration</b> .....	1.2
<b>System Components</b> .....	2.1
KMC 321 Mode Controller.....	2.1
KAS 297C Altitude/Vertical Speed Preselect.....	2.6
KAP 315A Annunciator Panel.....	2.8
Control Wheel Switch Assembly.....	2.9
Manual Electric Trim.....	2.9
KCI 310A Attitude Indicator.....	2.10
KPI 552/553B Horizontal Situation Indicator (HSI).....	2.12
EADI 40 Attitude Indicator.....	2.14
EHSI 40 Horizontal Situation Indicator.....	2.16
KCP 220 Flight Computer.....	2.18
Servo Actuator.....	2.18
KDC 222 Air Data Computer.....	2.19
<b>Normal Operation</b> .....	3.1
Preflight Test.....	3.1
Manual Electric Trim Test.....	3.1
EFS/Electromechanical Instrument Self Test.....	3.2
Flight Director Operation.....	3.3
Wings Level and Attitude Hold.....	3.4
Control Wheel Steering.....	3.4
Heading.....	3.5
Nav/Nav Arm.....	3.5
Approach/Approach Arm.....	3.5
Back Course.....	3.6
Altitude Hold.....	3.7
Altitude Select.....	3.7
Indicated Airspeed Hold.....	3.8
Vertical Trim Calibrations.....	3.8
Vertical Speed Select.....	3.8
Go-Around.....	3.9
Autopilot Operation.....	3.9
Yaw Damper.....	3.10
Half Bank.....	3.10
Soft Ride.....	3.10
<b>Emergency Operations</b> .....	4.1
Autopilot Emergencies.....	4.1
Manual Autopilot Shutdown.....	4.2
Engine Failures.....	4.2

---

---

<b>Operational Examples</b> .....	5.1
Climb to Assigned Altitude.....	5.1
Procedure Turn to ILS Approach.....	5.3
ILS Transition to Missed Approach.....	5.5
Localizer Back Course Approach.....	5.7
Long Range Nav Tracking.....	5.9
RNAV Capture and Track.....	5.11

---

# Introduction

---

The KFC 325 Flight Control System combines complete autopilot and flight director computation functions in a single computer. Its digital flight computer and integrated architecture enable the KFC 325 to determine aircraft control requirements sooner and execute them with greater smoothness and accuracy than previous autopilot systems. The implementation of digital solid state circuitry throughout the Flight Control System provides the pilot with maximum reliability while economizing the system weight and required installation space.

The KFC 325 is designed to optimize passenger and flight crew comfort, while still providing accurate control response in any flight situation. Wherever possible, autopilot-induced aircraft motions border on the lower limits of human perceptibility, ensuring exceptionally smooth flight. Many of the Flight Control System's maximum commandable values, however,

are determined for each individual aircraft during the Flight Control System certification process. Consult the KFC 325 Flight Manual Supplement for your aircraft to determine particular operation.

Internal safety monitors keep constant track of the KFC 325's status and provide signals for automatic shutdown of the autopilot or flight director in the event of a malfunction. In addition to reliability and light weight, the KFC 325 is designed to be easily maintained in the field. Qualified Bendix/King Service Centers are located around the world to provide assistance whenever necessary.

The KFC 325 will interface with four-inch electromechanical flight instruments as well as the latest electronic displays (EFIS). The KFC 325 is also capable of interfacing to many navigation systems, radar altimeters and other peripheral components.

# System Configurations

The KFC 325 Flight Control System is designed to locate all mode and function controls within convenient reach of the pilot and to provide clear, easily interpreted information displays. The KFC 325 has a number of configuration options including combinations of electronic and electromechanical flight instruments. The following equipment listings display sample EFIS/KFC 325 and electromechanical/KFC Flight Control Systems.

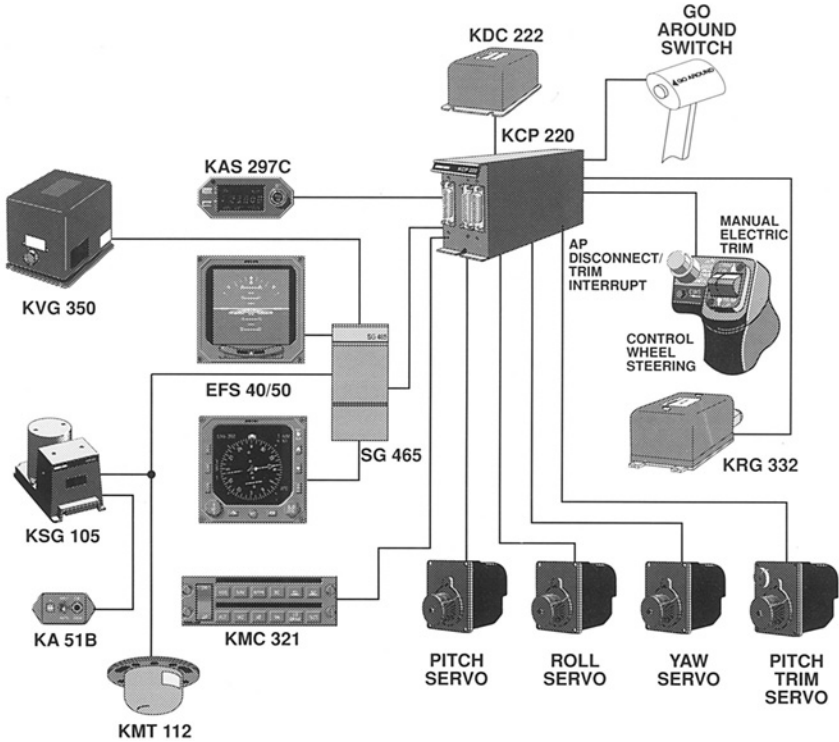

## EFS 40/EFS 50/KFC 325

### Cockpit Units

- KMC 321 Autopilot Mode Controller
- Control Wheel Switch Assembly
- Power Lever Go-Around Pushbutton
- EFS 40/EFS 50 Display Units
- KAS 297C Altitude/Vertical Speed Preselector (optional)

### Remote-Mounted Units

- KCP 220 Flight Computer
- KDC 222 Air Data Sensor
- Servo Actuators
- EFS 40/EFS 50 Symbol Generator
- KCS 305 Compass System
- KVG 350 Vertical Gyro
- KRG 322 Rate Gyro

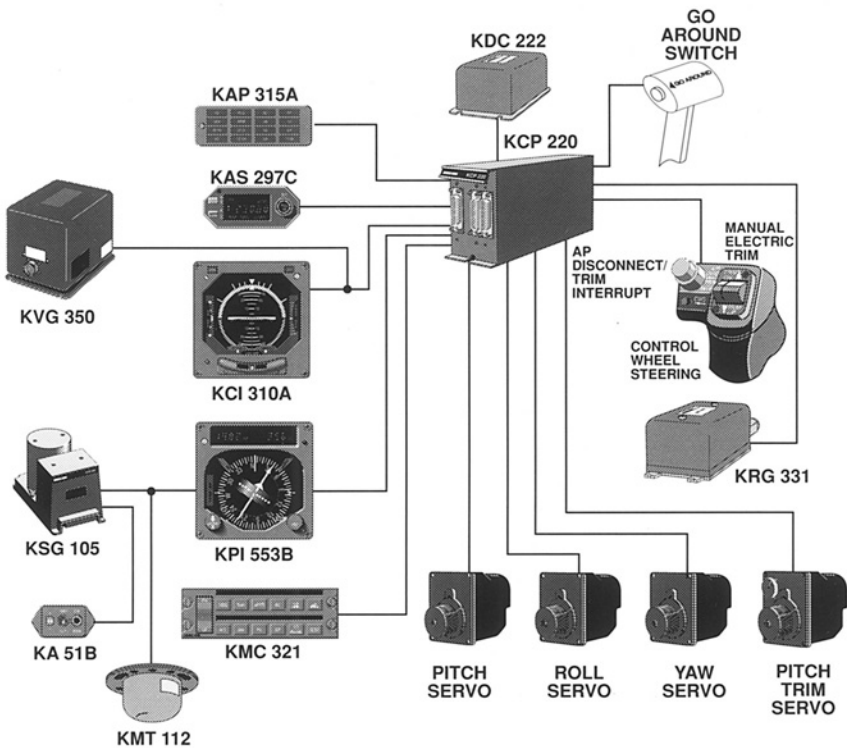

## Electromechanical Instruments/ KFC 325

### Cockpit Units

- KMC 321 Autopilot Mode Controller
- KAP 315A Annunciator Panel
- Control Wheel Switch Assembly
- Power Lever Go-Around Pushbutton
- Electromechanical Display Units
- KAS 297C Altitude/Vertical Speed Preselector (optional)

### Remote-Mounted Units

- KCP 220 Flight Computer
- KDC 222 Air Data Sensor
- Servo Actuators
- KCS 305 Compass System
- KVG 350 Vertical Gyro
- KRG 331 Rate Gyro

# System Components

---

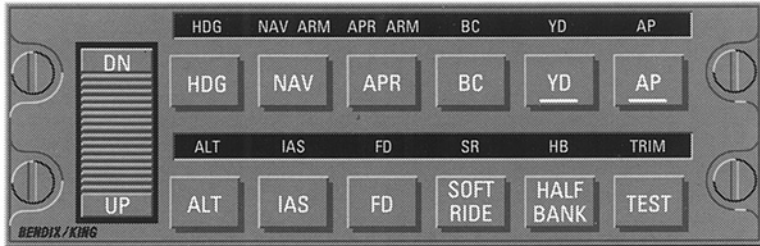

---

## KMC 321 Mode Controller

### Mode Annunciations

HDG (heading select) — Illuminates when heading select mode is engaged by the heading pushbutton.

NAV (capture and track selected navigation sensor) — Illuminates when Nav mode is engaged by depressing the NAV pushbutton and normally sequenced through Nav Arm. Nav can be used with VOR, RNAV, or Long Range Navigation sensors.

NAV ARM (preengage condition of NAV) — Illuminates when Nav mode is called for by the NAV pushbutton and course needle deflection exceeds the capture requirements of the Nav mode. While capture requirements (needle displacement and rate of needle displacement) are exceeded, the system will remain in ARM mode. When the requirement is achieved, the autopilot will capture and track the needle. Nav Arm allows a compatible

lateral mode to be used to intercept the desired course or track.

APR (capture and track selected navigation sensor with approach accuracy) — Illuminates when the Approach mode is engaged by depressing the APR pushbutton and when normally sequenced through Approach Arm. Approach mode may be used with Localizer, RNAV, or VOR approach sensors.

APR ARM (pre-engage condition of APR) — Illuminates when the Approach mode is called for by the APR pushbutton and course needle deflection exceeds the capture requirements of the Approach mode. Heading Mode may be used to intercept the desired course while the autopilot is Approach Armed.

---

BC (back course) — Illuminates when the Back Course mode is engaged. The BC button is optional when installed with an EFIS 40/50 system. Back Course automatically activates the Approach Arm/Capture mode and illuminates the respective annunciator.

YD (yaw damper) —Illuminates when yaw damp is engaged by depressing the YD or AP pushbutton.

AP (autopilot) — Illuminates when the autopilot is engaged by depressing the AP pushbutton.

ALT (hold current reference altitude) — Illuminates when the Altitude Hold mode is engaged by depressing the ALT pushbutton or by automatic sequencing through Altitude Capture when using the optional KAS 297C Altitude Preselect system.

IAS (hold current reference airspeed) — Illuminates when the Airspeed Hold mode is engaged by depressing the IAS pushbutton.

FD (flight director) — Illuminates when the FD button is pushed or by default when any flight director mode is engaged. The Flight Director mode is Wings Level and Pitch Attitude Hold.

SR (soft ride) — Illuminates when Soft Ride mode is engaged. SOFT RIDE can be activated only when the autopilot is engaged.

HB (half bank angle) — Illuminates when Half Bank mode is engaged. Half Bank can be activated only when the autopilot is engaged.

TRIM (trim warning light) — Illuminates continuously in the absence of trim power or if the system has not been preflight tested. An audible warning accompanies the light during a trim fault.

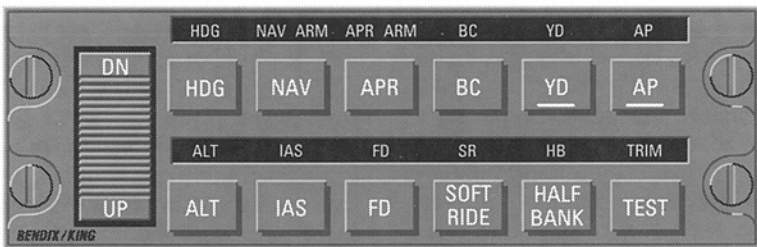



---

## Mode Select Pushbuttons



HDG (heading select) — Alternately engages and disengages Heading Select mode. Heading information is received from the position of the heading bug on the horizontal situation indicator (HSI). Depressing HDG will activate the flight director in Heading mode.



NAV (capture and track selected navigation sensor) — Alternately engages and disengages the Navigation mode. The flight director will command tracking of the coupled navigation receiver. Depressing NAV will activate the flight director. Consult the Aircraft Flight Manual Supplement for more information on the aircraft NAV switching scheme. Glideslope coupling is inhibited in the NAV mode.



APR (capture and track selected navigation sensor with approach accuracy) — Alternately engages and disengages the Approach mode. Glideslope coupling is allowed in the APR Cap-

ture or Track mode. Depressing APR will activate the flight director.



BC (back course) — Alternately engages and disengages the Back Course Approach mode. Back Course functions identically to the Approach mode except that the autopilot response to the localizer signal is reversed. Glideslope coupling is inhibited in the Back Course Approach mode. The Back Course pushbutton is optional in EFS 40/50 installations. With EFS 40/50, Back Course is determined from aircraft heading and the course pointer. The APR pushbutton activates Back Course mode in EFS 40/50 installations.



YD (yaw damper) — Alternately engages and disengages the Yaw Damp independent of the autopilots pitch and roll axes.

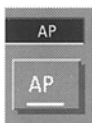

AP (autopilot) — Alternately engages and disengages the autopilot. Yaw Damp is automatically activated when the autopilot is engaged, however, Yaw Damp remains engaged if AP is pressed again.

DN/UP (vertical trim) — Controls the vertical axis of the autopilot. The rocker switch function is dependent upon the autopilot's active mode. Depressing and holding the switch up or down results in the following:



- In Pitch Attitude Hold mode the vertical trim switch adjusts the pitch attitude at a rate dependent upon the current airspeed. The maximum pitch rate is one degree per second.
- In Altitude Hold mode the vertical trim adjusts the altitude reference at a constant rate of 500 feet per minute.
- In Indicated Airspeed Hold mode the vertical trim switch adjusts the indicated airspeed reference at a constant rate of three quarters of a knot per second (0.75 kt/sec).

- In Vertical Speed Hold mode the vertical trim switch adjusts the vertical speed at a rate of one hundred feet per minute per second (100 fpm/sec).



ALT (hold current reference altitude) — Alternately engages and disengages Altitude Hold mode. Altitude Hold commands the aircraft to maintain the pressure altitude existing at the moment of selection. (Because the autopilot uses pressure altitude, the pilot must correct for altimeter changes during flight to insure barometrically corrected altitude).



IAS (hold current reference airspeed) — Alternately engages and disengages Indicated Airspeed Hold mode. The aircraft pitch command is varied by the flight director to maintain the selected airspeed during changing air conditions, power changes and/or aircraft configuration changes.



FD (flight director) — Engages the flight director in Pitch Attitude Hold and Wings Level mode. The pitch attitude is synchronized to the current aircraft pitch attitude. Pressing FD when flight director is engaged will disengage all flight director modes if the autopilot is not engaged.



HALF BANK— Engages the Half Bank autopilot mode. The autopilot's maximum commanded bank angle is reduced to one half the normal value. The half bank angle turns provide for extended passenger comfort. This mode is automatically disengaged when the Approach or Back Course Approach mode is activated.



SOFT RIDE — Engages the Soft Ride autopilot mode. Soft Ride mode decreases the autopilot gains thus decreasing the aggressiveness of the autopilot. The result of Soft Ride is a more comfortable ride in turbulent air conditions. Routine use of this mode during all flight conditions will result in less than optimum autopilot performance. Soft Ride mode is automatically disengaged when the Approach or Back Course Approach mode is activated.



TEST (preflight test)— When momentarily pushed, the preflight test button initiates the preflight test sequence. The test includes illumination of all annunciator lights, testing of rate and trim monitors, and testing of valid and dump logic within the computer. The AP annunciator will flash for approximately six seconds upon successful completion of the preflight test. An aural tone accompanies the flashing AP annunciation. The Autopilot mode will not be enabled until preflight test has been successfully passed.

---

## KAS 297C Altitude/Vertical Speed Preselect (Optional)



---

### Mode Annunciations

The display brightness is adjusted automatically for ambient light conditions by a photocell located on the face of the unit.

**VS (vertical speed)**— Illuminates when Vertical Speed Hold mode is engaged. The ENG pushbutton activates Vertical Speed Hold mode.

**ALERT (altitude alert)** — Illuminates 1000 feet prior to the selected altitude and turns off 300 feet prior to the selected altitude. Anytime the aircraft is more than 300 feet and less than 1000 feet from the selected altitude, the annunciator is visible. An aural tone accompanies the ALERT upon each of these annunciations. The ALERT will also momentarily illuminate when the selected altitude is reached.

**Altitude/Vertical Speed selection** — The gas discharge display shows the selected altitude from 100 to 50,000 feet or the selected vertical speed ranging from zero to 5,000 feet per minute up or down. Altitude is displayed while the small (inner) selector knob is in the “IN” position. Selected vertical speed is displayed when the small (inner) knob is in the “OUT” position. Rotating the concentric knobs change the selected vertical speed altitude.

**Vertical Speed UP/DOWN Caret (↕)**— Indicates whether the selected vertical speed is up or down.

**ARM** — Indicates that the Altitude Select mode is armed to capture the selected altitude. The ARM pushbutton activates the Altitude Select mode.

**NOTE:** *The display of the selected altitude is required to activate the Altitude Select mode. This assures pilot verification of altitude before activation.*

---

**CAPT (capture)** — Illuminates when the KAS 297C has switched the flight director from the active Pitch mode to Altitude Capture (CAPT). The Altitude Capture mode occurs prior to the point the flight director engages Altitude Hold. The point at which the flight director initiates Capture varies with vertical speed. The higher the rate of climb, the sooner Altitude Capture becomes active. At a low rate of climb, the activation of the Altitude Capture mode and the transfer to Altitude Hold occur almost simultaneously.

**FT/MIN (scale annunciator)** — Indicates FT/MIN when in Vertical Speed Hold mode. Displays FT when in the Altitude Select mode.

## Controls

**Vertical Speed/Altitude Select Knob** — Concentric knobs which allow easy selection of altitude or vertical speed. The inner (small) knob has an “IN” and “OUT” position.

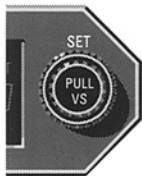

Altitude is displayed and selected when the small knob is in the “IN” position. When rotated, the small knob selects altitude in 100 foot increments with roll over into the 1000 digits. The outer (larger) knob selects 1000 foot increments with roll over into the 10,000 digits.

Vertical speed is displayed and selected when the small knob is in the “OUT” position. When rotated while positioned “OUT”, the small knob selects vertical speed in 100 feet per minute increments. The larger knob selects vertical speed in 1000 feet per minute increments up to a maximum of 5000 feet per minute.

**Altitude Select Mode (ARM) Button** — Engages Altitude Arm mode when depressed while the selected altitude is displayed. Altitude Select (ARM) mode will cancel Altitude Hold (ALT) mode if Altitude Hold is already engaged. Glideslope coupling will cancel Altitude Select (ARM) mode. The engagement of Altitude Hold by the pilot with the mode controller will cancel the Altitude Select (ARM) mode. Altitude Select (ARM) mode allows selection of a new altitude without deactivating the ARM.

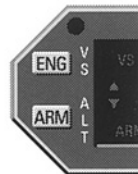

**Vertical Speed Mode (ENG) Button**— Engages Vertical Speed Hold mode when pressed while the selected vertical speed is displayed on the indicator. When depressed with no vertical speed value selected, the Vertical Speed Hold mode is engaged and the vertical speed is synchronized to the current vertical speed of the aircraft. The synchronized vertical speed is displayed momentarily.

---

## KAP 315A Annunciator Panel



---

### Display Features

All display brightness is adjusted automatically for ambient light conditions by a photocell located on the face of the unit.

FD, SR, HDG, HB, APR, APR ARM, IAS, BC, TRIM, ALT, NAV, and NAV ARM operate identically to the annunciations provided by the KMC 321 Mode Controller.

AP (autopilot) — Illuminates when the autopilot is engaged and flashes for five seconds upon autopilot disengagement.

YD (yaw damper) — Illuminates when the yaw damper is engaged and flashes for five seconds upon yaw damper disengagement.

GA (go around) — Illuminates when the Go-Around button is pushed engaging Go-Around mode.

GS (glideslope) — Illuminates when Approach mode is engaged and the glideslope beam has been captured.

---

## Control Wheel Switch Assembly



Mounted on the aircraft control wheel(s), the control wheel switch assembly provides pushbutton controls for the Control Wheel Steering function (flight director synchronization) and Autopilot Disconnect/Trim Interrupt. The manual electric trim split rocker switch is also located on the control wheel switch assembly.

### Control Wheel Steering

Pressing the CWS pushbutton disengages autopilot servo clutches, if engaged, and synchronizes the flight director command bars with the current vertical mode. Upon release of the pushbutton, the autopilot servo clutches reengage. The autopilot follows the new vertical reference (when CWS is released) and tracks the engaged lateral mode.

If the flight director is not engaged, pressing the CWS pushbutton activates the flight director in Pitch Attitude and Wings Level Hold. The flight director command bar will synchronize the aircraft to the attitude present upon pushbutton release.

### Autopilot Disconnect/Trim Interrupt Pushbutton

When pressed momentarily, disengages the autopilot and yaw damper and cancels all operating flight director modes. A tone will sound upon autopilot disconnect when the pushbutton is released.

When pressed and held, the Autopilot Disconnect/Trim Interrupt Pushbutton suppresses the autopilot disconnect tone and interrupts the electric trim power in addition to disengaging the autopilot, yaw damper, and flight director.

### Manual Electric Trim Control

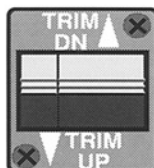

A split rocker switch controls manual electric pitch trim and disengages the autopilot. Moving both switches to the forward position activates nose down trim, while moving both rearward activates nose up trim. Activation of manual electric trim will cause the autopilot to disconnect.

Note: Certain installations may utilize the original manufacturers electric pitch trim control.

---

## Electromechanical Instruments KCI 310/KCI 310A

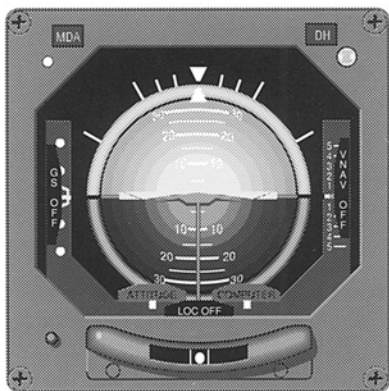

---

### Display Features

When the KFC 325 is installed in conjunction with conventional electromechanical flight instruments, the KCI 310 or KCI 310A Flight Command Indicator and KPI 552/553B Horizontal Situation Indicator provide displays of aircraft pitch and roll attitude, radio navigation information and steering commands computed by the flight control system.

**Roll Attitude Index**—Displays airplane roll attitude with respect to the roll attitude scale.

**Roll Attitude Scale** — Provides roll attitude measurement with scale markers at 10°, 20°, 30° and 60° of left and right bank.

**Symbolic Airplane** — A stationary display that provides a reference for pitch and roll attitudes displayed by the flight command indicator's movable background.

**Pitch Attitude Scale** — Provides pitch attitude measurement with reference to the symbolic airplane. Scale markers appear at 0°, 5°, 10°, 15° and 20° of up and down pitch attitude.

**Flight Director Command Bar** — Displays commands computed by the Flight Computer with reference to the symbolic airplane. Deactivation of the flight director by the flight crew will cause the command bars to swing out of view. If the flight director is inoperative due to detected malfunctions in the KCP 220 Flight Computer, the Command Bar swings out of view and the computer flag appears in the lower right portion of the indicator. The KFC 325 automatically disengages flight director and autopilot functions in event of a Flight Computer malfunction. Component failures within the Flight Command Indicator do not automatically disengage flight director or autopilot systems.



---

Decision Height Annunciator — Illuminates when the radar altimeter system is operating and the aircraft is at or below the currently selected radar altimeter decision height.

Attitude Flag — Warns that the displayed attitude information is invalid, due either to a malfunctioning remote vertical gyro, a KCI 310/A attitude power supply problem, or to a fault in the KCI 310 indicator servo loop.

Test Pushbutton — Initiates self-test of the flight command indicator and horizontal situation indicator. See Preflight Test Procedures for details.

Inclinometer — Displays aircraft slipping or skidding motions during maneuvers or flight in turbulence.

Computer Flag — Warns that the displayed steering command is invalid due to malfunction of the attitude indicator's command bar power supply and drive mechanism or because of internal failure of the flight computer. The KFC 325 automatically disengages autopilot and flight director functions when the detected malfunction is within the flight computer.

---

## KPI 553B Electromechanical HSI

### Display Features

DME/Radar Altitude Display — Displays DME information referenced to the active navigation waypoint. The DME display includes distance (nautical miles) and groundspeed (knots). During flight below 1000 feet with a compatible radar altimeter system operating, a radar altitude display automatically replaces groundspeed information.

Compass Card — Displays magnetic heading information received from the aircraft's compass system, with incremental marks spaced five degrees apart.

Lubber Line — Index mark for current aircraft magnetic heading.

Nav Flag — Warns that the received navigation signal is inadequate for course tracking. Some versions of the KFC 325 will not allow flight director or autopilot engagement if the Nav flag is displayed.

Course Pointer — Displays the magnetic course selected with the course selector knob on the KPI 553B. The course pointer remains stationary with respect to the compass card, except during course selection. Some Long Range Navigation systems are capable of autoslewing the course pointer.

Course Deviation Indicator — Indicates deviation from the selected course with reference to the course deviation scale. If the Nav flag is in view, the CDI display is invalid.

Course Deviation Scale — Measures displacement of the course deviation indicator in relation to a five-dot scale right and left of course centerline. Scale calibration is different for each Nav sensor.

In VOR, a five-dot CDI deviation indicates angular displacement of 10° from the selected course. RNAV full-scale deflection indicates a five-mile, linear displacement. In localizer, full-scale deflection indicates 2.5° deviation from the localizer centerline. RNAV Approach full-scale deflection indicates a 1.25-mile linear displacement from the selected course.

To/From Indicator Flag — Indicates direction of Nav reference relative to the selected course. The To/From flag is invalid if the Nav flag is displayed.

Symbolic Aircraft — Stationary symbol for display reference.

Glideslope Pointer — Indicates deviation from beam centerline during glideslope tracking, in relation to the Glideslope Scale.

Glideslope Scale — Indicates angular displacement from glideslope beam centerline.

Course Selector Knob — Moves the course pointer in the direction of knob rotation.

Groundspeed/Time-to-Station Select Pushbutton — Selects DME information for display in the right-hand portion of the indicator. If radar altitude is currently displayed, the pushbutton is automatically disabled.

Compass Flag — Warns that the compass display is invalid due to failure within the system's internal power supply, heading servo loop or remote directional gyro. The compass flag also swings into view during manual slaving adjustment or, momentarily, after selection of the slave position on the compass slaving accessory.

RMI Pointer — Displays the current magnetic bearing to the active waypoint, navaid or ADF ground station, as selected by the Nav/ADF selector lever on the KPI 553B.

Heading Bug — Indicates selected heading for flight director tracking in the Heading mode, as selected with the heading selector knob. Except during selection, the bug remains stationary with respect to the compass card.

Heading Selector Knob — Moves the heading bug on the compass card in the direction of selector rotation.

RMI Nav/ADF Selector Lever — References the RMI pointer to indicate magnetic bearing to the active waypoint or navaid or to the ADF ground station in use. Repositioning the lever causes a small "Nav" or "ADF" flag to be displayed adjacent to the heading selector knob.

Glideslope Flag — Warns that the glideslope signal is invalid.

## KPI 553B Electromechanical HSI



- |                        |                             |
|------------------------|-----------------------------|
| <b>A</b> DME Indicator | <b>F</b> Compass Flag       |
| <b>B</b> NAV Flag      | <b>G</b> RMI Pointer        |
| <b>C</b> Glideslope    | <b>H</b> HDG Select         |
| <b>D</b> Course Select | <b>I</b> RMI/NAV/ADF Select |
| <b>E</b> Lubber Line   |                             |

---

## EFS 40/EFS 50 Instrumentation

EFS 40 is four inch electronic instrumentation while EFS 50 is five inch instrumentation. EFS 40 and EFS 50 are functionally identical and therefore referred to as EFS 40/50 when describing either of the systems. The EFS 40/50 electronic attitude indicator (EADI) provides mode annuncia-

tion along the top of the EADI. Unlike dedicated annunciator panels, one area of the display is reserved for lateral modes and another for vertical modes. The engaged and armed modes are color coded for easy interpretation.

### EADI 40/50 ARTIFICIAL HORIZON AUTOPILOT/FLIGHT DIRECTOR MODE ANNUNCIATION

Engaged modes are annunciated in green along the top of the display, armed modes are annunciated in white. All annunciation meanings are identical to the descriptions provided by the mode controller.

The following figure displays flight control modes as supported by EFS 40/50 and the location in which they are displayed.

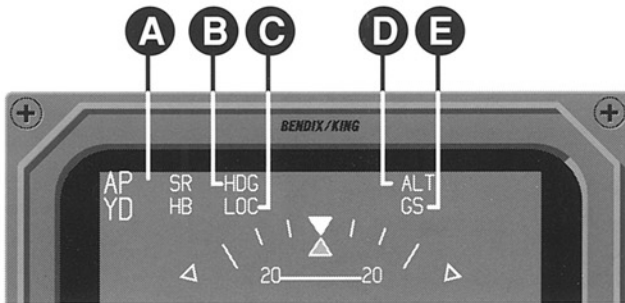

- A** Autopilot Engaged Modes
- B** Lateral Engaged Mode
- C** Lateral Armed Mode
- D** Vertical Engaged Mode
- E** Vertical Armed Mode

If the flight director data becomes invalid a red "FD" within a red box will be displayed at the right center of the display.

### Display Features

**AP (autopilot)** — When autopilot is engaged "AP" is displayed in green. Upon autopilot disengagement, the "AP" annunciation flashes red momentarily and is then removed.

**YD (yaw damper)** — is displayed in green when the yaw damper is engaged. Upon yaw damper disengagement "YD" turns red and flashes for five seconds.

**Engaged Lateral Mode** — The current engaged lateral mode is displayed in green. Possible annunciations in this position are: HDG, NAV, APR, LOC, BC or blank.

**Armed Lateral Mode** — The current armed lateral mode is displayed in white. When the mode goes from Armed to Coupled, the annunciation moves up to the engaged lateral mode position and changes to green. Possible annunciations are: NAV, APR, LOC, BC or blank.

**HB (half bank angle)** — is displayed in green whenever the Half Bank mode is engaged.

**CWS (control wheel steering)** — is displayed in green while the Control Wheel Steering Mode is active. The pilot gains manual control of the aircraft in this mode.

**SR (soft ride)** — is displayed in green whenever Soft Ride mode is engaged.

**Engaged Vertical Mode** — The current vertical mode is displayed in green. Possible annunciations in this position are: ALT, ALTC (Altitude Capture), IAS, VS, GS.

**Armed Vertical Mode** — The current armed vertical mode is displayed in white. When the mode goes from Armed to Coupled, the annunciation moves up to the engaged vertical mode position and changes to green.

## EADI 40

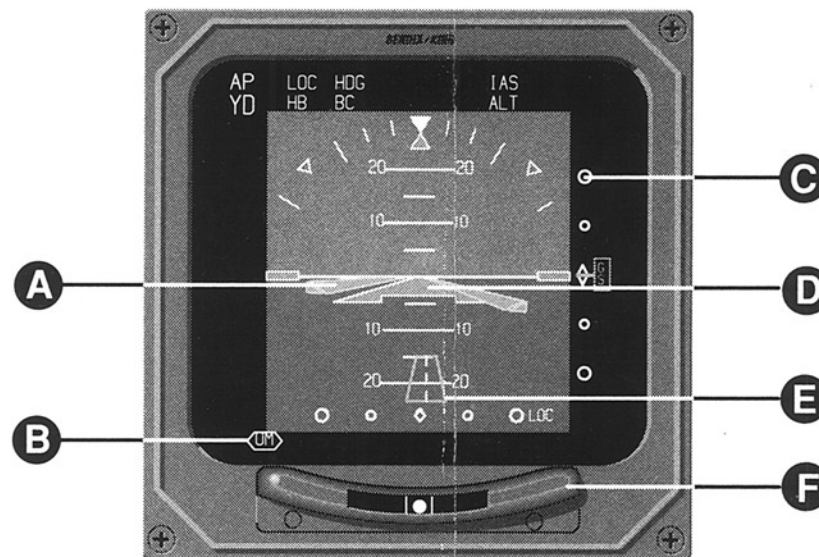

- A** Command Bar
- B** Marker Beacon Annunciator
- C** Glideslope Scale
- D** Symbolic Aircraft
- E** Rising Runway
- F** Inclinator

**NOTE:** Please refer to the EFS 40/50 Pilot's Guide for additional information on displays and use of the EFS 40/50 Electronic Flight Instrument System.

---

## EHI 40 Electronic Horizontal Situation Indicator

The EHI 40 Electronic Horizontal Situation Indicator has capabilities far superior to any electromechanical HSI currently available. Because the EHI 40 is so broad in its capabilities, this section only attempts to describe the EHI 40 features that apply to the KFC 325. For more information on the EHI 40, please refer to the EHI 40 Pilot's Guide.

**Compass Card** — Displays magnetic heading information received from the aircraft's compass system, with incremental marks spaced five degrees apart.

**Lubber Line** — Index mark for current aircraft magnetic heading.

**Nav Flag** — Warns that the received navigation signal is inadequate for course tracking. Some versions of the KFC 325 will not allow flight director or autopilot engagement if the Nav flag is displayed.

**Course Pointer** — Displays the magnetic course selected with the course selector knob. The course pointer remains stationary with respect to the compass card, except during course selection. The selected course is displayed numerically in the upper left corner of the indicator.

**Course Deviation Indicator** — Indicates deviation from the selected course with reference to the course deviation scale. If the Nav flag is in view, the CDI display is invalid.

**Course Deviation Scale** — Measures displacement of the course deviation indicator in relation to a five-dot scale right and left of course centerline. Scale calibration is different for different Nav sensors.

In VOR, full scale CDI deflection indicates angular displacement of  $10^\circ$  from the selected course. RNAV full-scale deflection indicates a five-mile, linear displacement. In localizer, full-scale deflection indicates  $2.5^\circ$  deviation from the localizer centerline. RNAV Approach full-scale deflection indicates a 1.25-mile linear displacement from the selected course.

**To/From Indicator Flag** — Indicates direction of nav reference relative to the selected course. The To/From flag is invalid if the Nav flag is displayed.

**Symbolic Aircraft** — Stationary symbol for display reference.

Glideslope Pointer — Indicates deviation from beam centerline during glideslope tracking.

Vertical Deviation Scale — Indicates angular displacement from the glideslope beam centerline.

TST/REF Pushbutton — Alternates Ground Speed and Time-to-Station information for display in the right-hand portion of the indicator. Holding this button activates annunciator testing.

DG Flag — Warns that the compass display is invalid due to failure within the system's internal power supply, heading servo loop or remote directional gyro. The compass flag also swings into view during manual slaving adjustment or, momentarily, after selection of the slave position on the compass slaving accessory.

Bearing Pointer — Displays the current magnetic bearing to the active waypoint, navaid or ADF ground station, as selected by the bearing pointer select.

Heading Bug — Indicates selected heading for flight director tracking in the Heading mode, as selected with the heading selector knob. Except during selection, the bug remains stationary with respect to the compass card.

Installations using the remote EFS 40/50 mode control panel have the Heading Course Selector Knob and the EFS 40/50 mode pushbutton on the control panel rather than on the display bezel. Heading and course sync operate by pulling the respective knob.

Heading Selector Knob — Moves the heading bug on the compass card in the direction of selector rotation. Depressing the pushbutton on the heading selector causes the heading bug to sync to the current aircraft heading.

Course Selector Knob—Moves the course pointer in the direction of knob rotation. Depressing the pushbutton on the course selector knob will sync the course pointer to the waypoint bearing. Course selection may be automatic (autoslew) when using a compatible Long Range Navigation Systems.

## EHSI 40

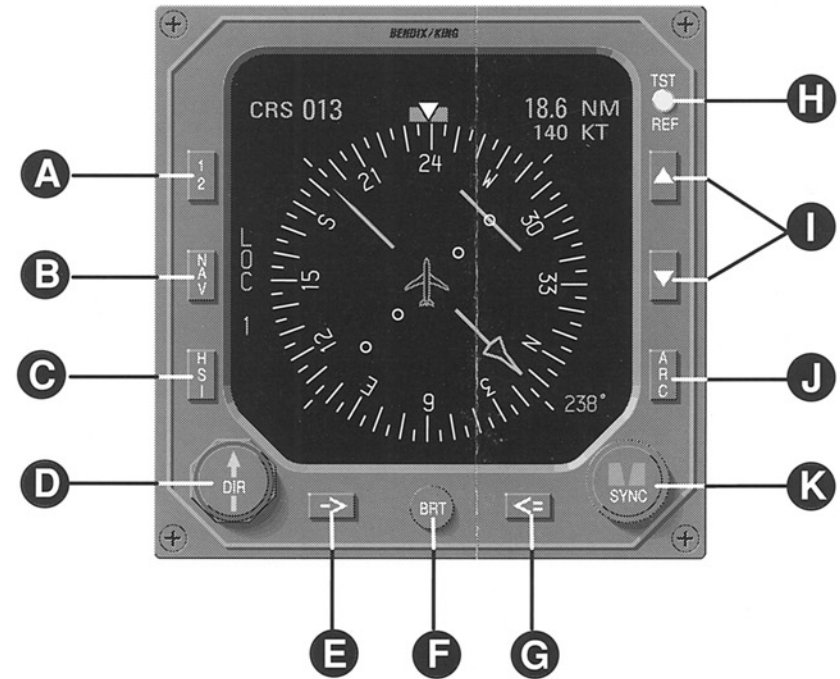

- A** System Select
- B** NAV Source Select
- C** 360° Mode Select
- D** Course Select
- E** #1 Bearing Pointer Select
- F** Brightness Control
- G** #2 Bearing Pointer Select
- H** GS/TTS/Test
- I** Range Select
- J** ARC Mode Select
- K** Heading Select

---

## Remote Mounted Units

### KCP 220 Flight Computer

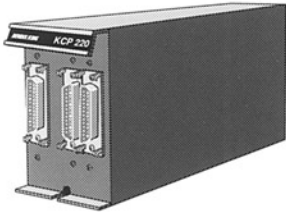

The KCP 220 Flight Computer provides all flight director and autopilot command computations as well as safety monitoring functions. Fully digital for reliability and repeatability, the KCP 220 employs individual axis processors for command computation. In addition, the KCP 220 generates audio alerts in case of autopilot disconnects.

The KCP 220 provides both analog and digital (ARINC 429) interfaces, making it compatible with both electro-mechanical (KCI 310/A/KPI 553B) and electronic (EFS 40/50) flight instrument systems.

### Servo Actuators

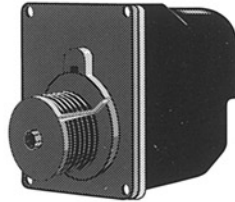

To manipulate trim surfaces, as well as elevator, aileron, and rudder controls, the KFC 325 employs KS 270 or KSA 370 series Servo Actuators installed in the aircraft's fuselage or wing and tail surfaces. Each servo assembly includes a drive motor and its associated circuitry, clutch mechanism, and mounting bracket.

The servo actuator uses a separate capstan assembly (KSM 275 or KSM375) that includes a calibrated slip clutch. The calibrated slip clutch allows the pilot to manually override the autopilot with the controls. The separate capstan allows removal of the servo without the need to dismantle the capstan/bridle cable assembly.



---

## KDC 222 Air Data Computer

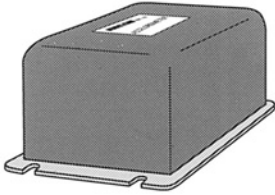

The KDC 222 Air Data Computer incorporates four sensors to provide air data and acceleration information to the KCP 220 Flight Computer. The altitude and airspeed sensors are used to tailor the Flight Control System to the aircraft's response based on airspeed (scheduling). A vertical acceleration sensor is used with Attitude hold modes while the lateral acceleration sensor provides information for yaw damper computations.

The KDC 222 also contains a monitor that can be used to disconnect the autopilot if vertical acceleration of the aircraft exceeds a set limit determined during autopilot certification.

# Normal Operations

## Normal Operations

Please note that operation of the Auto-pilot on the ground may cause the autotrim to run because of back force generated by elevator downsprings or pilot induced forces.

Some aircraft have preflight test sequences required in addition to the general procedures described here. See the FAA approved Aircraft Flight Manual Supplement for details on your particular aircraft. The KFC 325 must successfully complete the self test before the Autopilot mode is enabled.

### Preflight Tests

#### Autopilot Self Test

1. Allow 3-4 minutes after inverters and avionics power are on for gyros to erect and Heading and Attitude flags to clear.



2. Push the TEST button on the KMC 321 mode controller. The Trim Fail annunciator illuminates upon initial application of power to the autopilot and then extinguishes after successful completion of the self test. Note that the attitude/vertical speed preselect displays all digit segments, flags, and annunciators momentarily. The preflight test concludes with the AP annunciator flashing twelve times accompanied by the autopilot disconnect tone.

3. Upon successful completion of the test all displays return to normal.

#### Manual Electric Trim Test

Manual electric trim operation requires both sides of the trim split switch to be depressed in the same direction simultaneously. The following procedure describes a test for the manual electric trim system. Perform this test on the ground.

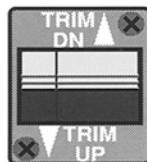

1. Push the left side of the split switch unit to the fore and aft positions while leaving the right side untouched. The trim wheel should not move. The left side of the split switch provides power to engage the trim servo clutch. Rotate the trim wheel manually against the engaged clutch to check the pilot's trim overpower capability.

2. Depress the right side of the split switch unit to the fore and aft positions while leaving the left side untouched. Again, the trim wheel should not move. Normal trim wheel force should be required to move the trim wheel manually. The right side of the switch controls the servo direction.

---

3. Depress both sides of the split rocker switch forward. Check to insure that the trim wheel is running in the direction of nose down trim. Depress both sides of the split rocker rearward for nose up trim. Verify that the trim is correctly running in the nose up direction.

### EFS 40/50 Self Test

Depress and hold the TST/REF pushbutton to test all of the annunciations. See the EFS 40/50 Pilot's Guide and your Aircraft Flight Manual Supplement for specific test procedures.

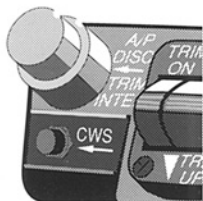

4. Move both sides of the trim switch fore and aft. Depress the autopilot disconnect/trim interrupt switch while the trim wheel is moving. The trim wheel should stop turning while the autopilot disconnect/trim interrupt switch is held.

### Electromechanical Instrument Self Test

KCI 310/KCI 310A test button—press and hold

1. Attitude display indicates 10° nose up 10° right bank.
2. Attitude Flag on KCI310/KCI310A and Compass Flag on KPI553B swing into view.
3. In some installations a lamp test of autopilot annunciations is performed separately.

---

## Flight Director Operations

The KMC 321 mode controller provides complete selection of flight director modes, ranging from basic pitch attitude and wings level hold through advanced lateral navigation and vertical speed functions. Continuous, automatic performance monitoring ensures the accuracy and reliability of flight director commands to provide efficient, safe, and effective guidance in almost any situation.



KMC 321

The KFC 325 can engage in only one horizontal and one vertical tracking mode at a time. A number of methods are available to activate the flight director. It is not necessary to press the FD pushbutton prior to selecting a flight director mode. Depressing any one of the HDG, NAV, APR, BC, ALT, or IAS pushbuttons on the mode controller will activate the flight director in the respective mode. Depressing the FD mode controller pushbutton or the control wheel steering (CWS) pushbutton on the yoke will activate the flight director in a pitch attitude (synchronized to the current pitch) and wings level hold mode.

To cancel any active flight director mode, either select an alternate lateral/vertical tracking mode or press the active mode's selector key. Go-Around is an exception, as the remote pushbutton provides the engage function only. When the flight director is operating with no lateral or vertical mode se-

lected, the KFC 325 automatically engages in Wings Level and Pitch Attitude Hold.

While the mode controller is the central control unit for flight director mode selection, the altitude/vertical speed preselector and the Go-Around pushbutton also provide control of certain flight director modes.

Annunciator lamps illuminate above the mode controller pushbuttons and on the annunciator panel or EFS 40/50 EADI.

### Flight Director (FD)



Activating the Flight Director mode with the mode controller pushbutton initiates flight director functions independently of the autopilot or yaw damper.

The flight director (FD pushbutton) will engage Wings Level and Pitch Attitude Hold and will move the command bars into view synchronized to the current aircraft pitch attitude. Depressing the CWS pushbuttons is an alternative way to activate the flight director.

It is not necessary to press the flight director pushbutton prior to selecting another flight director mode. Selecting any flight director mode initiates flight director commands in that mode.

Press the FD pushbutton again to disengage the flight director. The flight director will not disengage if the autopilot is in use.

---

### Wings Level and Pitch Attitude Hold (Not Annunciated)

Wings Level and Pitch Attitude Hold, the flight director's default modes, engage automatically in the absence of any active tracking modes. Upon initial activation, the flight director generates commands for wings-level flight at the existing pitch attitude. Wings Level and Pitch Attitude Hold may be activated by depressing the CWS pushbutton on the yoke or the FD pushbutton on the mode controller.

Target pitch attitudes may be modified by adjusting the aircraft's attitude manually while pressing the CWS pushbutton. Alternatively, Pitch Attitude Hold commands may be modified through use of the Vertical Trim control on the mode controller (see System Components, page 2.4).

After release of the CWS pushbutton or the Vertical Trim control, the flight director displays commands to maintain the pitch attitude selected.

Selecting any lateral or vertical tracking mode cancels Wings Level or Pitch Attitude Hold, respectively. Either mode may be used in conjunction with any Arm mode to provide flight guidance for course or altitude intercepts.

### Control Wheel Steering (CWS)

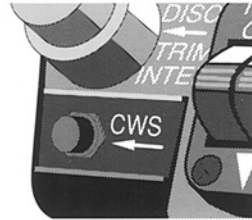

CWS allows the crew to synchronize flight director commands in pitch. The CWS pushbutton activates the flight director in Wings Level and Pitch Attitude Hold mode if pressed and no other modes are active. When the flight director mode selected is Pitch Attitude Hold, Altitude Hold, Airspeed Hold, or Vertical Speed Hold, CWS will cause a new reference attitude, altitude, airspeed, or vertical speed to be established upon release.

The CWS pushbutton disengages the servo clutches giving the pilot full authority of the aircraft while the aircraft is coupled to the autopilot. Release of the CWS pushbutton reestablishes the lateral mode and incorporates the new reference in the vertical mode.

---

## Heading (HDG)



In Heading mode the flight director commands roll attitudes necessary to track the heading indicated by the bug position on the HSI.

Activating the Heading mode cancels any other horizontal tracking mode. The Heading mode may be used during Nav Arm or Approach Arm sequences, but disengages automatically in favor of the Nav or Approach functions.

## Nav (NAV/NAV ARM)



With the Nav mode engaged, the flight director commands roll attitudes necessary to track the course selected on the Nav indicator. The KFC 325 adjusts the gains or aggressiveness of the autopilot based on the selected sensor to provide optimum performance.

Upon selection, the Nav mode engages either Nav Arm or Nav Capture, depending upon the aircraft's proximity to the selected course and its closure rate. While any horizontal tracking mode may be engaged in conjunction with Nav Arm to provide intercept guidance, initiation of the Nav Capture sequence cancels the coexisting mode. If the aircraft's deviation from the se-

lected course centerline is sufficiently small, or if the rate of closure with the new course is sufficiently high, the flight director initiates the Nav Capture sequence immediately.

The Approach mode responds to course needle deviations more aggressively and operates independent of the Nav mode. The Approach mode should be activated when flying a coupled approach to insure maximum autopilot performance. Glideslope is inhibited in Nav mode.

## Approach (APR ARM/APR)

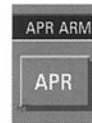

The Approach mode is similar to the Nav mode with regard to Arm. However, in Capture and Track, the Approach mode is more sensitive to course deviations and responds to the deviations faster than operation in Nav mode. Approach/Approach Arm is activated by depressing the APR pushbutton on the mode controller. The APR pushbutton automatically activates the Back Course mode in EFS 40/50 installations. Back Course is determined from the course needle selection and the current heading.

Upon initial selection, the Approach mode engages in either Approach Arm or Capture, depending on the aircraft's closure rate and proximity to the selected course. Due to the increased sensitivity of the deviation display in the Approach mode, the flight director may initiate turn commands before

---

any needle movement is shown on the course deviation indicator. Selecting the Approach mode after the aircraft has already passed the point at which Approach Capture would normally begin may result in initial course overshoot due to the flight director's roll command limits.

Approach Capture automatically activates Glideslope Arm, Capture, and Track sequences during ILS front course approaches. Upon capturing glideslope, GS is annunciated on the EFS 40/50 display or on the annunciator panel. Glideslope capture deactivates any other vertical mode. Glideslope coupling is inhibited during back course operation. Exercise caution when Approach Arming the autopilot at significant distances from the localizer or prior to making your final turn for the localizer intercept. Side lobes or false echoes of the localizer are often present on transmitters. The autopilot may incorrectly couple and track these false signals. Any horizontal tracking mode may be employed during Approach Arm phases, but will cancel automatically upon initiation of Approach Capture and Track.

### **Back Course (BC)**

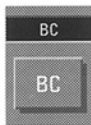

The Back Course mode allows the KFC 325 to correctly track the localizer inbound on the back course. This mode also allows the autopilot to track

outbound on the localizer front course. Back Course mode is a submode of the Approach mode and may be activated by either of two methods. One method is to set the flight director in Approach mode (APR pushbutton) and then select Back Course (BC). The alternative is to directly depress BC. The Back Course mode automatically activates the Approach mode. The BC pushbutton is optional in EFS 40/50 installations because the EFS 40/50 system makes the course determination based on the current heading and course selection. Selection of Approach, depressing APR, will automatically activate Back Course in EFS 40/50 installations.

It is essential that the course pointer on the navigation display always be aligned with the localizer front course. The Flight Computer reverses the course information selected by the course pointer when in the Back Course Approach mode. Even when using a number two Nav to fly a localizer approach, always select the localizer front course with the omni bearing selector (OBS). An example back course approach is explained in the Example Operations section.

---

### Altitude Hold (ALT)



In the Altitude Hold mode the flight director commands pitch attitudes for tracking of the aircraft pressure altitude current at the moment of mode selection. Altitude Hold can be entered directly by depressing the ALT pushbutton on the mode controller or in conjunction with the Altitude Select mode. Engaging Altitude Hold directly during a climb or descent will cause the aircraft to fly through the desired altitude and then recover from the other side. For this reason, Altitude Hold activation is most effective when vertical speed is less than 500 fpm. Selecting Altitude Hold after the Altitude Select mode has been engaged cancels Altitude Select and causes the ARM annunciator to extinguish. The flight director will command the aircraft to hold the altitude present at the moment of mode selection. When operating in environments requiring barometrically corrected altitude, the pilot may have to adjust Altitude Hold to compensate barometric pressure changes during flight. Altitude Hold commands may be modified by holding the autopilot vertical trim rocker switch in the up or down position either momentarily or for several seconds at a time. Continuous vertical trim operation causes the flight director to command a climb or descent, as appropriate, at 500 feet per minute until the switch is released.

### Altitude Select (ALT ARM)



The Altitude and Vertical Speed Preselect system is a KFC 325 option. The Altitude Select mode arms the flight director for capture and tracking of altitudes selected with the altitude/vertical speed preselector. A separate vertical mode, must be engaged to provide flight guidance to the point of altitude capture. Upon reaching the altitude capture point, the selected vertical mode will cancel and the flight director will transition to Altitude Capture and then Altitude Hold. Altitude Select is activated by setting the preselector to the desired altitude and then depressing the ARM pushbutton. During ALT ARM, the Selected Attitude may be changed without deactivating the ALT ARM mode. During transitions to armed altitudes the altitude/vertical speed preselector briefly sounds an alert tone when the aircraft passes within 1000 feet of the selected altitude. In addition, an ALERT annunciator illuminates on the altitude/vertical speed preselector when the aircraft is between 1000 and 300 feet above or below the armed altitude. The annunciator illuminates again, briefly, when the aircraft reaches the selected altitude. Subsequently, alerts are provided if the aircraft deviates



more than 300 feet from the selected altitude.

To disengage Altitude Select, press the ALT selector key on the attitude/vertical speed preselector.

### Indicated Airspeed Hold (IAS)



Engaging the Indicated Airspeed Hold Mode causes the flight director to command pitch attitudes to maintain the current indicated airspeed.

Airspeed commands may be altered through use of the vertical trim rocker switch at the rate of 0.75 knots per second or by using CWS. The airspeed value is derived from the outputs of the Air Data Computer.

### Vertical Trim Calibrations



Vertical trim controls the vertical axis commands to the flight director. The function of the rocker switch is dependent upon the active flight director mode. Depressing and holding the rocker in either direction results in the following:

**Pitch Attitude Hold:** Adjusts pitch attitude. The specific value of adjustment is dependent on the aircraft airspeed. The maximum rate of pitch adjustment is one degree per second.

**Altitude Hold:** Maintains 500 fpm climb or descent until released. Altitude present when released is held.

**Indicated Airspeed Hold:** Adjusts the indicated airspeed at a rate of 0.75 knots per second until released.

**Vertical Speed Hold:** Adjusts vertical speed at a rate of 100 fpm per second until released.

### Vertical Speed (VS)



In the Vertical Speed mode the flight director commands pitch attitudes to maintain the vertical speed selected in altitude/vertical speed preselector. The vertical speed is entered by rotating the extended preselect knob (PULL VS). Vertical Speed is activated by depressing the ENG pushbutton while the desired vertical speed is displayed on the altitude/vertical speed preselector. Verify that the preselected vertical speed displays the caret  $\diamond$  in the appropriate direction.

If no vertical speed value is displayed, depressing ENG will cause the flight director to command a climb or descent

---

at the rate current upon selection. In addition, vertical speed commands may be modified through use of the autopilot Vertical Trim at the rate of 100 fpm per second during continuous trim operation. The CWS button may also be used to adjust the vertical speed. The VS select knob changes selected vertical speed by 100 fpm on the small knob and 1000 fpm on the large knob.

When Vertical Speed Hold mode is activated, the VS annunciation is illuminated on the attitude/vertical speed preselector.

### Go-Around Mode (GA)



Pressing the Go-Around Pushbutton disengages the autopilot and causes the flight director to command a nose-up, wings-level attitude. The exact pitch attitude commanded is selected for each aircraft type during KFC 325 certification. The autopilot and any lateral tracking mode may be subsequently reengaged without cancelling Go-Around. The Go-Around pushbutton is generally located on the throttle, yoke, or panel.

## Autopilot Operations

All of the flight director modes of operation are directed to the autopilot when the autopilot is engaged. The autopilot is engaged by depressing the AP pushbutton on the mode controller. The autopilot cannot be activated if the flight director is not operating properly. To engage modes using the mode controller, press the corresponding pushbuttons. To disengage, press the pushbutton a second time. Annunciator lamps illuminate above the mode controller pushbutton and on the Annunciator Panel or EFS 40/50 EADI to indicate engaged modes. The KFC 325 employs an aural alert tone upon autopilot disengagement.

### Autopilot (AP)



Depressing the Autopilot pushbutton initiates autopilot control of the pitch, roll and yaw axes, provided the flight director is active.

The yaw damper, if not previously engaged, engages automatically upon autopilot activation. The autopilot follows the active flight director commands upon engagement.

Pressing the Autopilot pushbutton a second time cancels its operation. The flight director and yaw damper, however, remain engaged until they are cancelled individually.

---

In case of engine loss consult the aircraft flight manual supplement for procedures regarding autopilot operation.

### Yaw Damper (YD)

The Yaw Damper pushbutton alternately engages and disengages yaw damper functions independently of the autopilot. If the yaw damper was previously engaged through autopilot activation, pressing the pushbutton cancels the function.

The yaw damper augments aircraft stability by opposing uncommanded motion about the yaw axis and provides turn coordination. In case of engine power loss consult the aircraft flight manual supplement for the procedures specified for yaw damper operation.

### Half Bank (HB)



With the Half Bank mode engaged, the autopilot limits the maximum roll attitude command to one-half of the normal limit. Half Bank is activated by depressing the Half Bank pushbutton on the mode controller.

Half Bank may be engaged in conjunction with any flight director tracking mode with the exception of Approach. Half Bank may be employed at the same time as Approach Arm, but will cancel automatically upon initiation of the Approach Capture sequence.

### Soft Ride (SOFT RIDE)



With the Soft Ride mode engaged the autopilot reacts softer than normal to deviations from the planned flight track or aircraft attitude. Soft Ride is most useful to reduce the command activity in turbulent air.

Soft Ride may be engaged any time a generally smoother flight is more desirable than immediate corrections of slight altitude, heading, or airspeed deviations.

The specific degree of command softening employed in the Soft Ride mode is determined for each aircraft type during KFC 325 certification. Soft Ride may be engaged with any mode as long as the autopilot is engaged, with the exception of Approach. Soft Ride may be employed at the same time as Approach Arm, but will cancel automatically upon initiation of the Approach Capture sequence.

# Emergency Operation

---

## Emergency Procedures

The KFC 325 monitors autopilot operations continuously through sensors that monitor the aircraft's pitch attitude and acceleration, as well as servo motor operation. If monitors in the KFC 325 detect a problem, the autopilot will disconnect, illuminate a flashing AP annunciation, and provide an aural disconnect tone. If an autotrim failure is detected, the TRIM annunciator on the mode controller illuminates and the trim fail tone sounds. If a manual electric trim failure is detected, the TRIM annunciator illuminates and the trim fail tone sounds. The malfunction continues until the pilot takes action to stop it.

In event of autopilot or flight director malfunction pay primary attention to basic aircraft control prior to attempting to diagnose the exact nature or cause of system failure. Once aircraft control is assured, the crew may attempt to reengage the affected autopilot or flight director mode by pressing the related mode pushbutton.

### Autopilot Emergencies

In the event of an autopilot malfunction, the flight crew should immediately execute the following procedures:

1. Airplane Controls — GRASP FIRMLY AND REGAIN AIRCRAFT CONTROL.
2. Simultaneously PRESS AND HOLD the Autopilot Disconnect/Trim Interrupt Pushbutton located on the yoke. Autopilot and yaw damper will disconnect and trim power is interrupted.
3. While HOLDING the Autopilot Disconnect/Trim Interrupt Pushbutton, pull the autopilot circuit breaker.
4. After the autopilot has been disengaged, DO NOT REENGAGE. Resume normal manual flight operations.
5. Refer to aircraft flight manual supplement for procedures.

---

## Manual Autopilot Shutdown

It is important to realize the different ways an autopilot can be manually disconnected. The following list describes the alternate methods to manually shut down the autopilot.

1. Autopilot Mode pushbutton — PRESS AP, THEN RELEASE.

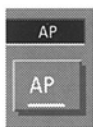

2. Autopilot Disconnect/Trim Interrupt Switch — PRESS AND HOLD. Both autopilot and yaw damper will disengage.



3. Manual Electric Trim Switch — MOVE TO FORE OR AFT POSITION, THEN RELEASE. Autopilot disengages; flight director remains operational.

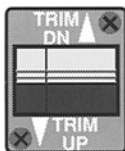

4. Go-Around Pushbutton — PRESS, THEN RELEASE. Autopilot disengages; flight director commands a nose-up attitude. The Go-Around pushbutton is generally located on the power lever, yoke, or panel.

5. Autopilot Circuit Breaker — PULL.

6. Autopilot Power Switch (if installed) —TURN OFF.

7. Avionics Master Switch — TURN OFF. Consult aircraft flight manual supplement for your aircraft. Turning off the avionics master will cause loss of power to all connected avionics in the aircraft.

## Engine Failure Emergency (Autopilot Coupled )

1. Disengage the autopilot.
2. Follow the engine inoperative procedures in the airplane operating handbook.

# **Operational Examples**

---

Take Off and Climb

ILS Approach

Missed Approach

Localizer Back Course Approach

Long Range Nav Tracking

RNAV Tracking



## Take Off and Climb

The following examples describe possible applications of the KFC 325 Flight Control System, other applications may be available. Consult the Aircraft Flight Manual Supplement for aircraft specific operating instructions and limitations.

\*Indicates application of the optional KAS 297C Altitude/Vertical Speed Preselector.

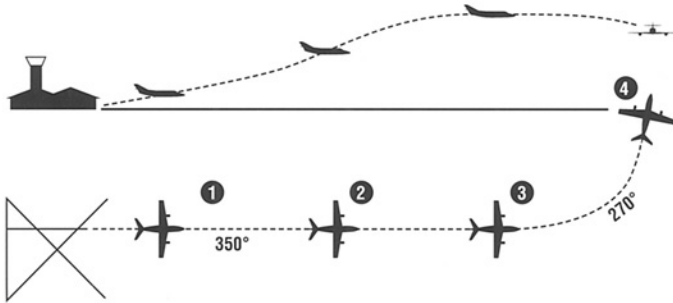

Objective: Depart the assigned runway, turn to a 270° heading and climb to 3000 feet. Prior to take off perform the autopilot preflight test as described on page 3.1.

1. After normal take off procedures are complete and the aircraft is rotated to its appropriate climb attitude, the CWS button may be pushed to activate the flight director and sync Pitch Attitude Hold to the current pitch attitude. The flight director will display the set pitch and wings level command until another mode is selected. The heading bug is positioned at the desired or assigned heading (in this case 270°).

\*The KAS 297C is preset to the assigned altitude (3,000 feet) and the appropriate vertical speed for the climb entered by turning the extended knob of the altitude preselector.

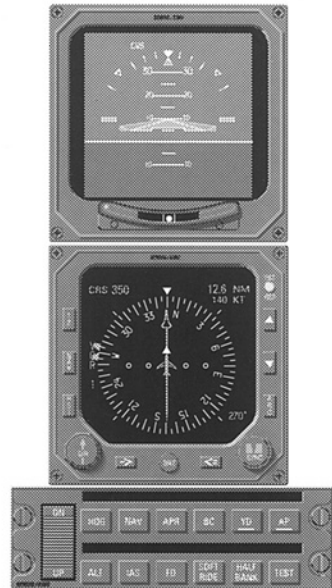

2. When desired, the Heading mode and preferred vertical mode (IAS Hold, Pitch Altitude Hold, or Vertical Speed Hold) are activated. This will result in flight director commands to turn to the selected heading and pitch to the appropriate vertical attitude.

The aircraft will respond to the flight director commands as soon as the autopilot is engaged.

\*To activate Altitude Select for the flight director depress the ARM pushbutton on the attitude preselector while the selected altitude is displayed. For flight director commands corresponding to the selected vertical speed, depress the ENG pushbutton after the selected vertical speed has been entered in the preselector.



3. At a safe altitude, depress the AP pushbutton on the mode controller so the autopilot will engage and respond to the command bars. The autopilot then follows the HSI heading bug and adjusts pitch attitude to maintain the selected vertical mode.

\*At 1,000 feet from the selected altitude, an aural tone will momentarily sound and the ALERT annunciator will illuminate on the altitude/vertical speed preselector until the aircraft is within 300 feet of the selected altitude.



4. The aircraft reaches the selected altitude (3,000 feet) and the ALT pushbutton is depressed engaging Altitude Hold. The 270° heading has been acquired.

\*Prior to reaching the selected altitude, the autopilot transitions from Altitude ARM to Altitude Capture (CAPT) and then engages Altitude Hold automatically. There is no need to depress the ALT pushbutton on the mode controller if the altitude/vertical speed preselector is used. An ALERT annunciation will be momentarily present when the selected altitude is reached.

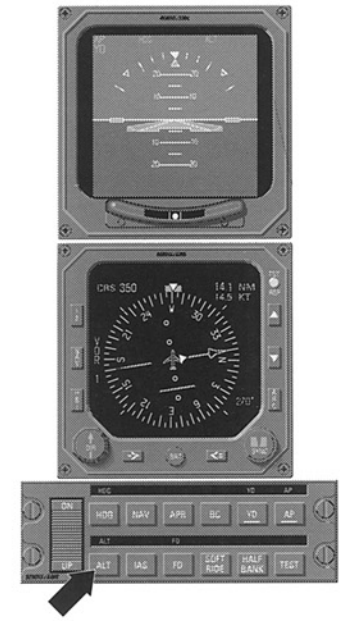



## Procedure Turn to an ILS Approach

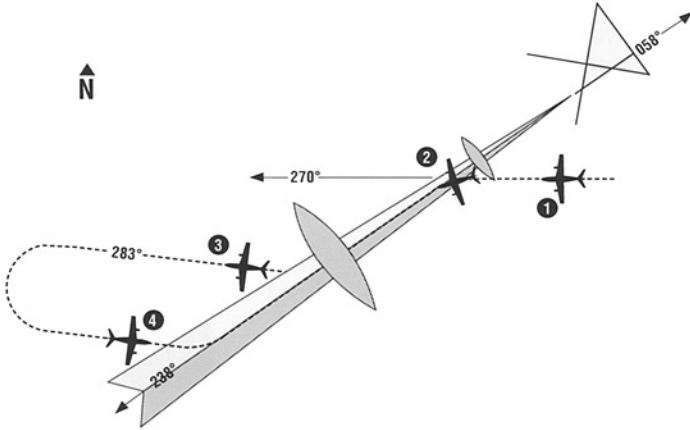

Objective: Fly outbound, execute a procedure turn, and fly a coupled ILS approach.

1. With Heading and Altitude Hold engaged, the aircraft is flying 270° to intercept the localizer outbound. The localizer front course (inbound) of 58° is selected with the HSI course pointer. Since the outbound heading is opposite of the localizer front course, BC is depressed. Installations with EFS 40/50 depress APR because BC is automatically determined. The BC button is optional in EFS 40/50 installation. The course pointer is always selected to the localizer front course to obtain correct course information for the autopilot and proper “fly to” indications on the HSI. Back Course mode is used to go outbound opposite the front course.



2. When the computed capture point is reached, the BC Approach Coupled mode is automatically activated and a left turn outbound on the localizer is commanded by the flight director and satisfied by the autopilot. Note the left/right deviations are directional.



3. Prior to the procedure turn, position the heading bug to 283° which gives the 45° angle for the initial procedure turn heading. At the point where the procedure turn is to be initiated, depress the HDG pushbutton to engage the Heading Select mode. The autopilot will turn the aircraft to the heading bug heading (283°).

During the procedure turn outbound, the deviation bar shows pictorially that the aircraft is flying away from the localizer centerline at a 45° angle.



*Note: When activating Approach Arm, it is important that the aircraft be relatively close to and not making any turns away from the localizer. Side lobes or false echoes are often present from the localizer transmitter. These false signals may cause the autopilot to approach couple prior to reaching the actual localizer signal.*

4. At the point specified to begin the procedure turn inbound, select 103° with the heading bug for a 180° turn toward the localizer front course. The deviation bar shows pictorially the course you are to intercept and the angle of intercept. Depress the APR pushbutton to arm the Approach mode. Automatic capture will occur to direct the aircraft on the localizer.



5. The autopilot is following the flight director commands which maintain localizer centerline tracking. Once Approach Coupled, Glideslope is automatically armed. The point of glideslope capture is based on the glideslope deviation and the rate of change of glideslope deviation. Both pitch and roll are commanded by the flight director to maintain glideslope and localizer track.

Consult your Aircraft Flight Manual Supplement for limitations such as flap extension amounts approved for coupled approaches.

6. At decision height, disengage the autopilot or press the Go-Around pushbutton while adding power. The autopilot is not to be coupled below 200 feet above the ground. The Go-Around button is generally found on the power lever, yoke, or panel.



## ILS Transition to Missed Approach

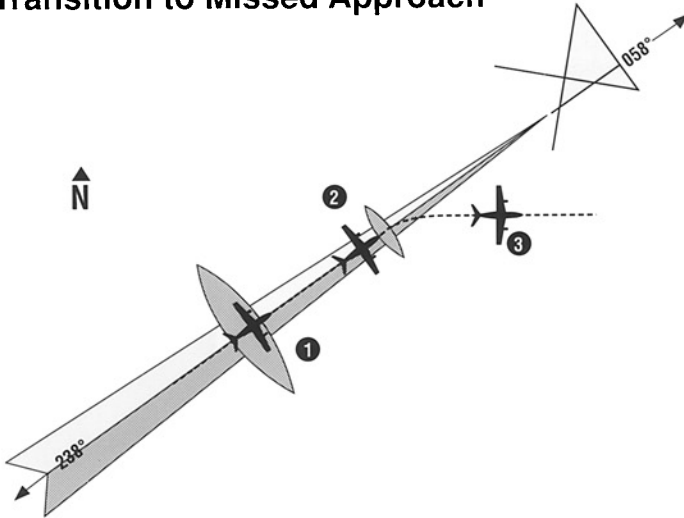

Objective: Transition from an ILS approach to missed approach and go around. Continuing the maneuver on the preceding page, Approach Coupling occurs and the Glideslope mode is annunciated as it is coupled.

1. The autopilot is following the flight director commands which maintain localizer centerline tracking. At the outer marker the glideslope pointers are approximately at midpoint. At the Glideslope capture point, Glideslope automatically transitions from Arm to Coupled and Altitude Hold is disengaged. The capture point calculation is based on glideslope deviation and rate of deviation change. The flight director then commands tracking of glideslope and the autopilot follows by adjusting pitch attitude.



2. At Decision Height a missed approach is initiated by pressing the Go Around button as power is increased. The Go Around button is usually located on the power lever, yoke, or panel. This disengages the autopilot and causes the flight director to command a specified nose up and wings level attitude. At the discretion of the crew, the autopilot may be reengaged by depressing the AP pushbutton on the mode controller.



3. The heading bug had been previously set to the missed approach heading of 90°. Depressing the HDG pushbutton activates Heading mode and causes the flight director to command a turn to that heading. Pitch attitude may be adjusted from the Go Around angle by using CWS and moving the yoke, depressing the vertical trim control, engaging IAS Hold, or by activating vertical speed mode. Any of which will cancel the Go-Around mode.

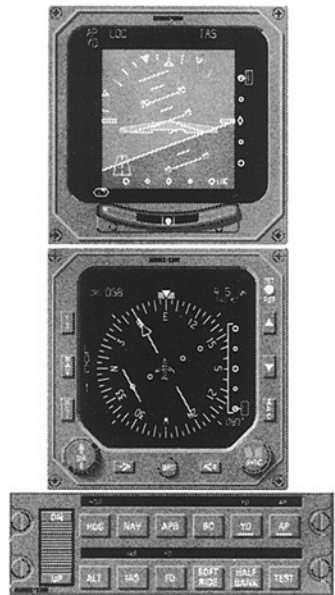

## Localizer Back Course Approach

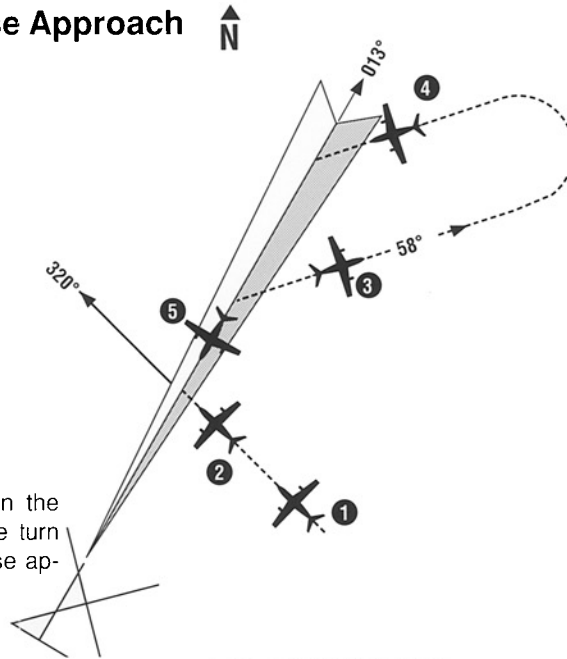

**OBJECTIVE:** Fly outbound on the localizer, complete a procedure turn and fly the localizer back course approach to the airport.

1. In Heading Select and Altitude Hold mode with the localizer frequency selected in the active navigation receiver, the aircraft is flying 320° to intercept the localizer. The localizer front course of 013° is selected with the HSI course pointer. Remember that the course pointer is always selected to the localizer front course to obtain correct “fly to” indications on the HSI.

As the aircraft nears the localizer, the NAV pushbutton is depressed to arm the Nav mode so that the localizer will be captured and tracked. Nav mode inhibits glideslope coupling. The capture point computation is based on deviation and deviation rate of change.

**NOTE:** Always select the navigation course pointer or OBS to the inbound course of the localizer front course.



2. When the computed capture point is reached, the Nav mode is automatically activated and a right turn outbound on the localizer is commanded by the flight director and satisfied by the autopilot.



3. Prior to the procedure turn, the heading bug is positioned to 58° which is the 45° initial procedure turn heading. At the point where the procedure turn is to be initiated, depress the HDG pushbutton to engage Heading Select mode and the autopilot will turn the aircraft to the direction of the heading bug (58°).

During the procedure turn outbound, the deviation bar shows pictorially the aircraft flying away from the localizer centerline at a 45° angle.



4. At the point specified to begin the procedure turn inbound, select 238° with the heading bug for a 180° turn toward the localizer front course. The deviation bar shows pictorially the course you are to intercept as well as the angle of intercept. Depress the BC pushbutton to arm the Back Course Approach mode. (APR activates Back Course automatically in EFS 40/50 installations). Note that the left/right deviations of the course deviation bar give "fly to" indications. Automatic capture will occur to direct the aircraft on the localizer.



5. The autopilot is following the flight director commands which maintain localizer centerline tracking. A number of options are available to help you descend while the autopilot remains coupled.

With Pitch Attitude Hold and Back Course Approach mode, the CWS button or vertical trim can be depressed for selection of desired pitch attitude during descent. Prior to reaching the minimum descent altitude, the ALT pushbutton can be depressed to activate Altitude Hold.



**Note:** *If intercepting the localizer without a procedure turn exercise judgement when arming the Back Course mode. Side lobes exist on many localizers which may cause the autopilot to capture the incorrect signal. Depress the BC pushbutton when your position is relatively close to the localizer.*

Using the attitude/vertical speed preselector, enter the minimum descent altitude and the vertical speed at which you wish to descend. Depress the ARM pushbutton on the preselector with the desired altitude being displayed. Depress ENG to establish the constant vertical speed descent. The selected altitude will automatically be captured when reached.



6. Disengage the autopilot or press the Go-Around pushbutton at the missed approach point. The Go-Around pushbutton will disengage the autopilot and command a specific climb attitude for the flight director. The Go-Around pushbutton is generally located on the power lever, yoke, or panel. At the pilots discretion, the autopilot may be reengaged. The autopilot is not to be coupled below 200 feet above the ground.



**Note:** *Consult your Aircraft Flight Manual Supplement for limitations such as flap extension approved for coupled approaches.*

---

## Long Range Nav Tracking

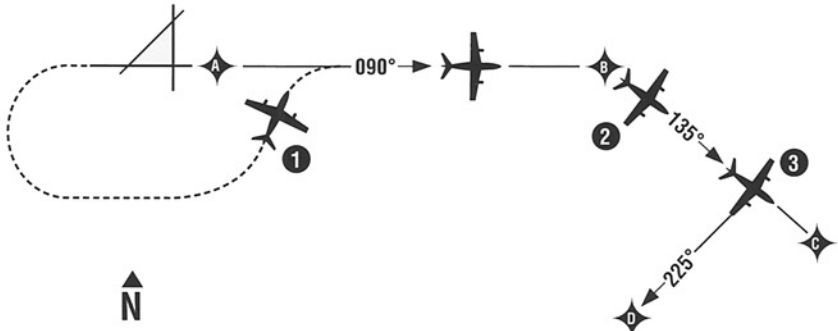

Objective: Intercept the desired course and complete a “direct to” or change of course operation after passing waypoint “B” while coupled to a Long Range Nav.

1. The autopilot is engaged in Heading Select and Altitude Hold mode. A flight plan from waypoint “A” to “B” to “C” is entered in the Long Range Nav. The course pointer is selected to 090° and Nav Arm is activated. The aircraft is heading 045° to intercept the course. As the course deviation bar moves toward the center, the Nav signal is captured and the autopilot tracks the course to the active waypoint.



2. As the aircraft crosses waypoint "B", the course pointer must be rotated to reflect the course or bearing to the new active waypoint (135° in this case).



3. The pilot changes the active waypoint to "D" via a "Direct To" operation with the Long Range Nav. The HSI course pointer must be rotated to 225° to reflect the bearing to "D". The autopilot will then correctly track the course to waypoint "D".

*Note: Certain Long Range Nav devices (ie: KNS 660) have a digital output of the course to the active waypoint and can automatically slew the course pointer to the correct position. If this feature is not available on your Long Range Nav, the course pointer must be manually rotated as described.*





# RNAV Capture

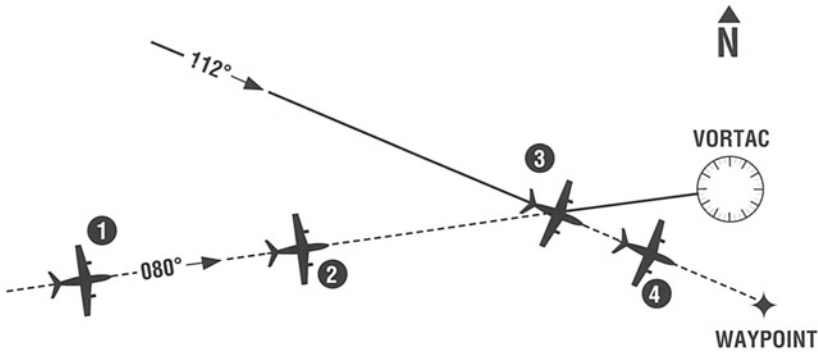

Objective: Intercept and track the 112° course to the RNAV waypoint.

- 1. The aircraft is flying to a VOR on an airway in HDG mode, heading 080°.
- 2. A waypoint has been established in the RNAV. The HSI course needle is selected to the desired 112° course to the waypoint. Nav Arm is activated so that the autopilot will automatically transition from Heading to Nav mode when the Nav deviation has entered the capture zone.



3. The capture sequence starts when Nav mode automatically couples, cancelling Nav Arm and Heading modes. The autopilot is turning the aircraft to the right.



4. The aircraft has completed its turn to the 112° course. A wind correction produces a heading of 105°. The HSI displays the seven degree “crab” angle required to maintain the 112° RNAV course.



## ***BENDIX/KING***

Honeywell International Inc.  
One Technology Center  
23500 W. 105th Street  
Olathe, Kansas 66061  
Phone (913) 782-0400

© 2000 Honeywell International Inc.  
006-08478-0000

---

**Honeywell**